



By removing a bolt the basket is fast and easy removed. The purpose is to make the manoeuvre ability easier in difficult circumstances.



1-2. The functional design of the covering boxes for batteries, hydraulic and electric control facilitates and rationalises service and maintenance.

3. Straightforward operation of all functions from the control panel in the basket.



Safety clamp for protection of joystick.



4. All DENKA lifts have an outrigger control device ensuring that the lift is only operable when weight is on each support leg.



## Narrow lift series from DENKA LIFT - the compact platform for inside and outside jobs

This narrow DL-lift series was specially designed for rental companies, larger industries, shopping centres, airports, etc.

The compact lift construction with a width of merely 890 mm and a detachable basket makes lift operations even possible in places where lifts of other brands fail.

Thanks to the self-drive system the lift is easy to manoeuvre and move from one working position to another by one operator only and without the use of additional aids.

The three-wheeled-drive is standard and allows easy transport even under problematic conditions, like for instance extreme climbing angles or soft surfaces. Working tasks on sites are therefore no problem at all.

Max. working heights are from 18,8 up to 22 metres. Automatic restriction of the load moment ensures optimum reach to suit the load in the basket.

DL19/22N are very flexible lifts which, as standard, are supplied for battery operation. As extra accessories, the lifts of this series can be delivered with diesel engine either with or without generator.

All DENKA LIFTS meet the most stringent safety standards. The electrical and hydraulic system feature double safety devices, the cylinders have hose break valves, and all the movements of the lift have a pressure control valve safety system.

## Technical data

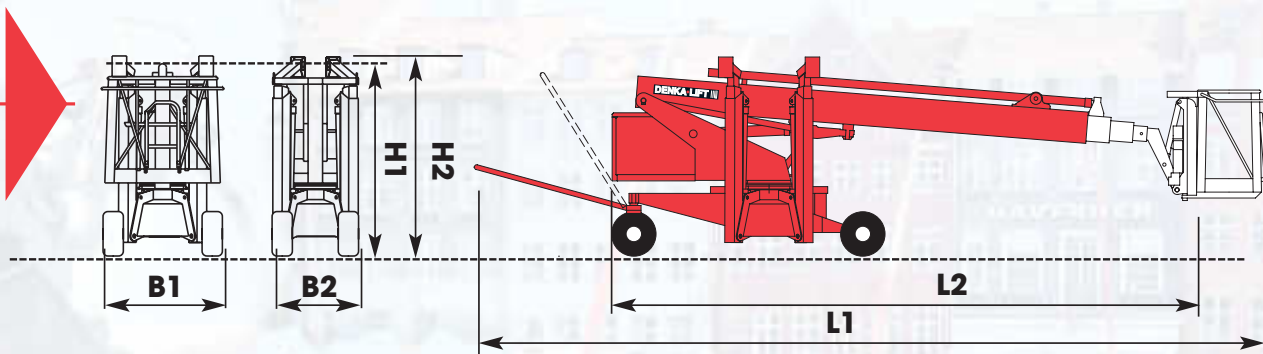

### Outrigger cross section

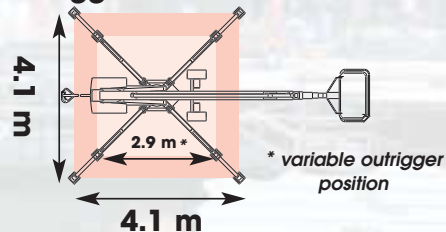

### Max. working height

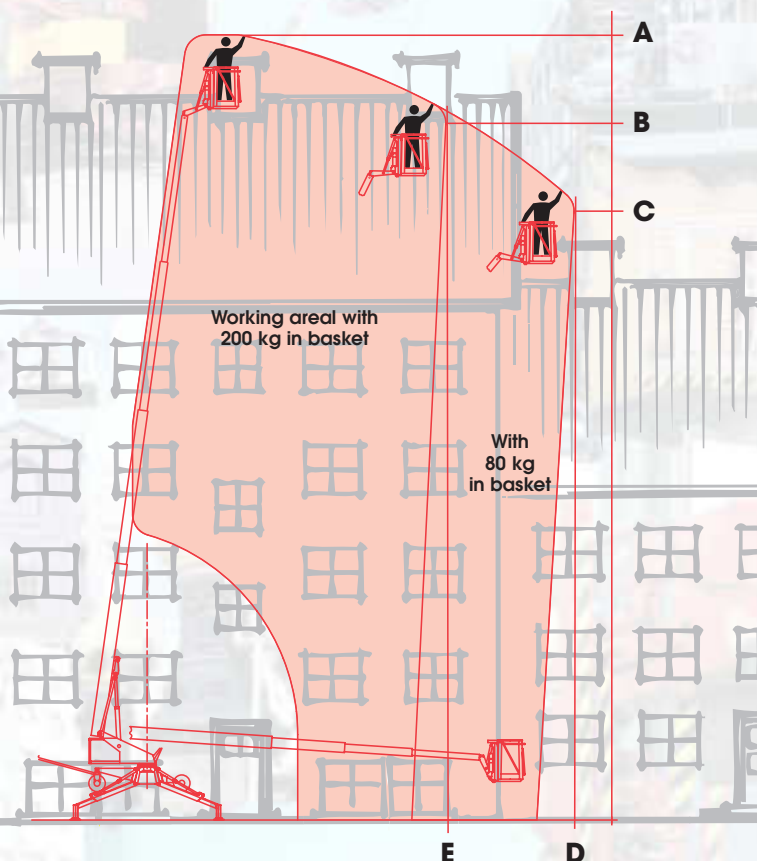

	Standard model DL19N	DL22N
<b>Capacity</b>		
Max. working height A	18.8 m	21,9 m
Working height B	15.8 m	19.5 m
Working height C	13.6 m	17.5 m
Max. reach D	10.9 m	11.8 m
Reach E	8.4 m	8.3 m
Max. load in basket	200 kg	200 kg
Slew movement	cont. 360°	cont. 360°
<b>Transport dimension</b>		
Length L1	7000 mm	7900 mm
Length L2	5580 mm	6525 mm
Height H1	1995 mm	1995 mm
Height H2	2140 mm	2140 mm
Width B1	1195 mm	1195 mm
Width B2	890 mm	890 mm
Net weight standard	2075 kg	2300 kg
<b>Driving specifications</b>		
Speed / high	1,00 m/s	1,00 m/s
Speed / low	0,35 m/s	0,35 m/s
Max. climbing angle	12° / 21%	12° / 21%
Turning radius	2,6 m	2,6 m

### STANDARD EQUIPMENT:

- Rotating detachable alu basket 1200 mm
- Battery operation
- Proportional control
- Hydraulic outriggers
- Hydraulic wheel drive
- ELCB 30 mA
- Hour counter
- Charging key
- Switch for raising boom during selfdrive

### EXTRA ACCESSORIES:

- Variable outrigger position
  - Current supply 50 (80) A/24 V\*
  - Outlets for Water/air in the basket\*
  - Petrol generator\*
  - Yellow rotating light
  - Height limiting system 2 steps
  - D.engine 5,0 KW w. charging generator 230V / 2,2 Kw\*
  - Special colours
  - Yellow flashing light on outriggers
  - High capacity battery\*
  - Biological degradable hydraulic oil
  - Adjustable Basket from ground level
- \*increase in weight